

Safety – Operation – Maintenance

Keep this document in a safe place

Read and understand this manual before operating your vacuum

CLAYTON
Dustless Made Simple™

Hornet Exp Air

Dust Ignition Proof Pneumatic Vacuum

CE Ex II 3 D T85°C

Models with Prefix: 500-400, ACE-300, ACE-400, ACE-500, ACE-1000

- Designed for use in Explosive Dust Atmospheres
- Designed for use in Class II Division 2 Groups E, F & G Locations
- Designed for use in ATEX Category 3D Zone 22
- Dry Recovery Only



Scan this QR code for online instructions and documentation, or visit www.ClaytonHowTo.com

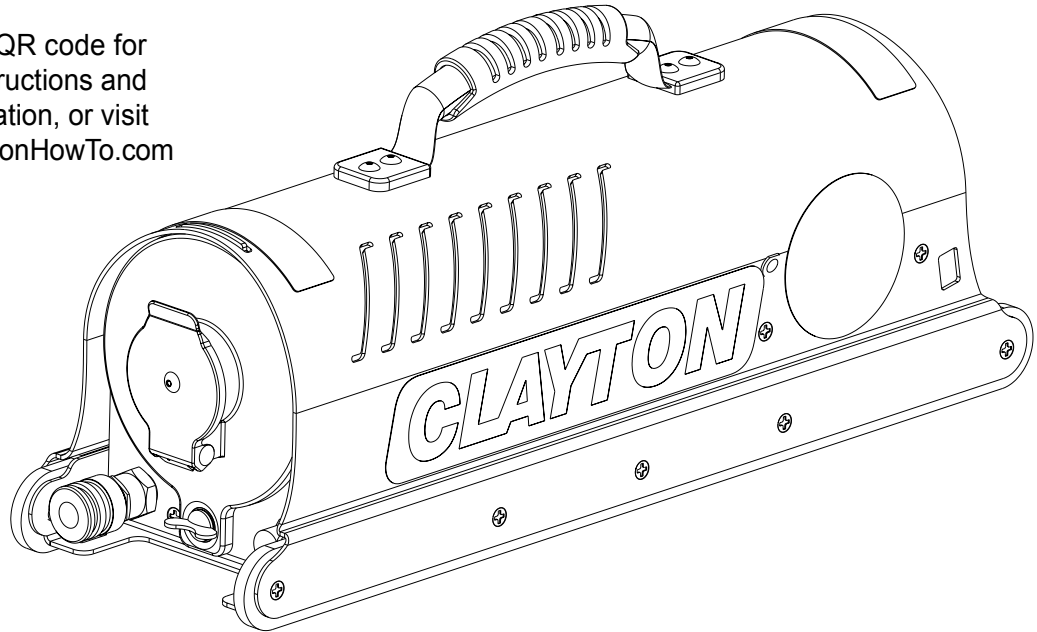

⚠ WARNING

SAFETY LEGEND



⚠ WARNING

Read and understand operator's manual before using this equipment.



⚠ WARNING

Eye protection is required when operating this equipment.



⚠ WARNING

Hearing protection is recommended when operating this equipment.



⚠ WARNING

Respiratory protection is recommended when operating this equipment.

⚠ WARNING

- A HEPA Filter must be installed in this vacuum at all times
- If this vacuum is used to collect hazardous material, appropriate personal protective equipment may be required
- If this vacuum is intended for dust ignition proof operation, it must be used with supplied or recommended accessories from Clayton Associates
- Any alteration to this equipment by a third party will nullify its warranty

January 2019

TABLE OF CONTENTS

Table of Contents.....	2
Applications & Environments.....	2
What's Included.....	3
Specifications & Requirements.....	3
Getting Started.....	3
Compressed Air Fittings.....	4
Dynamic Power Control.....	4
Differential Pressure Gauge.....	5
Before Each Use.....	6
Bag Filter Change.....	8
Safe Filter Change.....	9
HEPA Filter Change.....	11
Backpack Harness.....	12
Illustrated Parts Breakdown.....	13
Limited Lifetime Warranty Terms and Conditions.....	17
Declaration Of Conformity.....	18

APPLICATIONS & ENVIRONMENTS

Meets the European ATEX requirement for use in:

The ATEX marking certifies that the vacuum can be used in the presence of combustible or conductive dusts.

Group II / Category 3D / Zone 22

Non-mining (Group II) Combustible Dust (Category 3D) is abnormally present (Zone 22)

Meets the North American NEC / NFPA requirements for use in:

Class II / Div 2 / Group E

Atmospheres containing metal dust (Class II Group E) is abnormally present (Div 2)

Class II / Div 2 / Group F

Atmospheres containing carbon, black coal or coke dust (Class II Group F) is abnormally present (Div 2)

Class II / Div 2 / Group G

Atmospheres containing flour, starch or grain dust (Class II Group G) is abnormally present (Div 2)

▲ WARNING

Do not use this equipment for cleaning or extracting fuel residues from any vehicle or equipment.

Do not use this equipment for cleaning or extracting live sparks or burning embers.

Grounding Instructions

This vacuum must be connected to an earth ground source with the grounding cable included. If the vacuum should come in contact with an external electrical source, grounding provides a path of least resistance for electrical current to reduce the risk of electrical shock.

Bonding Instructions

The work piece must be bonded to the same earth ground as the vacuum. This ensures that the vacuum and the work piece are at the same electrical potential to eliminate static discharge between them.

Tools And Attachments

This equipment is only intended for dust-ignition proof operation if it is used with the proper conductive hose and tools provided by Clayton. Any alteration to this equipment by a third party will nullify its warranty.

WHAT'S INCLUDED

Hornet Pneumatic Vacuums ship with the following items:

- Hornet Pneumatic Vacuum
- Conductive Filter Bags (Installed)
- Conductive HEPA Filter (Installed)
- HEPA 12 Month Timer Card (Installed)

ACE kits ship with the following optional accessories:

- Conductive 1/2" Compressed Air line
- Grounding / Bonding Cable
- Conductive Filter Bags
- Continuity Tester
- Conductive Combination Air/Vac Hose
- Backpack Harness

Use only the following Clayton consumables and accessories:

Hornet Filters

Model	
Bags	690-A0031
HEPA	627-516H

Hornet Accessories

Model	
Conductive Compressed Air line	922-A08H30
Grounding Bonding Cable	900-A001-30
Continuity Tester	925-200
Combination Air/Vac Hose	67X-AVHW1616-08

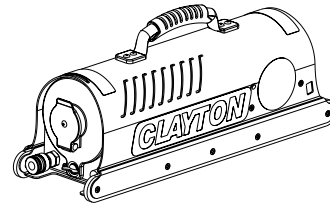

Hornet Air Pneumatic Vacuum



Conductive HEPA Filter

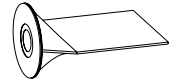

Conductive Filter Bags

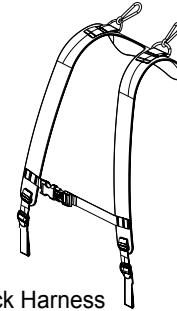

Backpack Harness

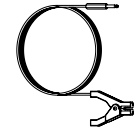

Ground Cable



Continuity Tester

SPECIFICATIONS & REQUIREMENTS

Weight	10 lbs (4.5 kg)
Dimensions.....	6.25 x 6 x 20 in (15.8 x 15.2 x 50.8 cm)
HEPA Filter Efficiency.....	99.97% @ 0.3 µm (H13)
Filter Bag Efficiency.....	95% @ 0.5 micron
Compressed Air Consumption.....	60 SCFM (102 SCM/H)
Compressed Air Supply Pressure.....	90-120 PSI (6.2 - 8.3 bar)
Vacuum Flow	60 SCFM (102 SCM/H)
Vacuum Suction.....	180 in/H ₂ O (45 kPa)
Sounds Pressure Level	<70 dBA

GETTING STARTED

1. Remove and identify the vacuum, consumables, and accessories included in the box

2. Visually inspect vacuum to ensure that no parts are missing or damaged

3. Activate the HEPA Filter Timer

- The HEPA Timer Card is attached to the handle
- Follow the directions on Timer Card to activate

4. Familiarize yourself with the vacuum

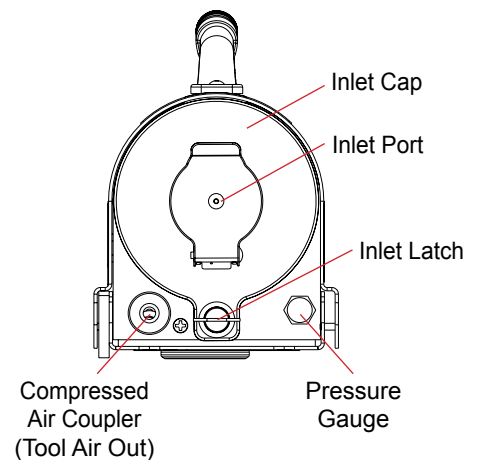
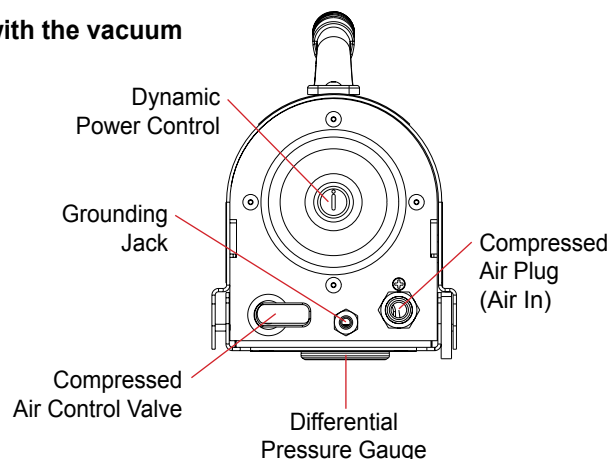

COMPRESSED AIR FITTINGS

The vacuum has the following compressed air requirements to function properly

- Compressed air must be clean, dry, and oil free to prevent blockage of the pneumatic system
- Compressed air line and fittings must have a minimum diameter of 1/2in

Compressed Air Plug (air in)

The Vacuum is supplied with a 1/2in stainless steel industrial interchange compressed air plug for connection to your compressed air supply.

The Compressed Air Plug may be changed to another nominal 1/2in style if required

- Remove the compressed air plug with either a 7/8in deep socket or 7/8in open end wrench
- Install a new compressed air plug

Compressed Air Coupler (air out)

The Vacuum is supplied with a 1/4in brass high flow compatible industrial interchange compressed air coupler. This coupler provides convenient pass through compressed air for an air tool connected to the vacuum.

The Compressed Air Coupler may be changed to another nominal 1/4in style if required

- Remove the compressed air coupler with a 3/4in open end wrench
- Install a new compressed air coupler

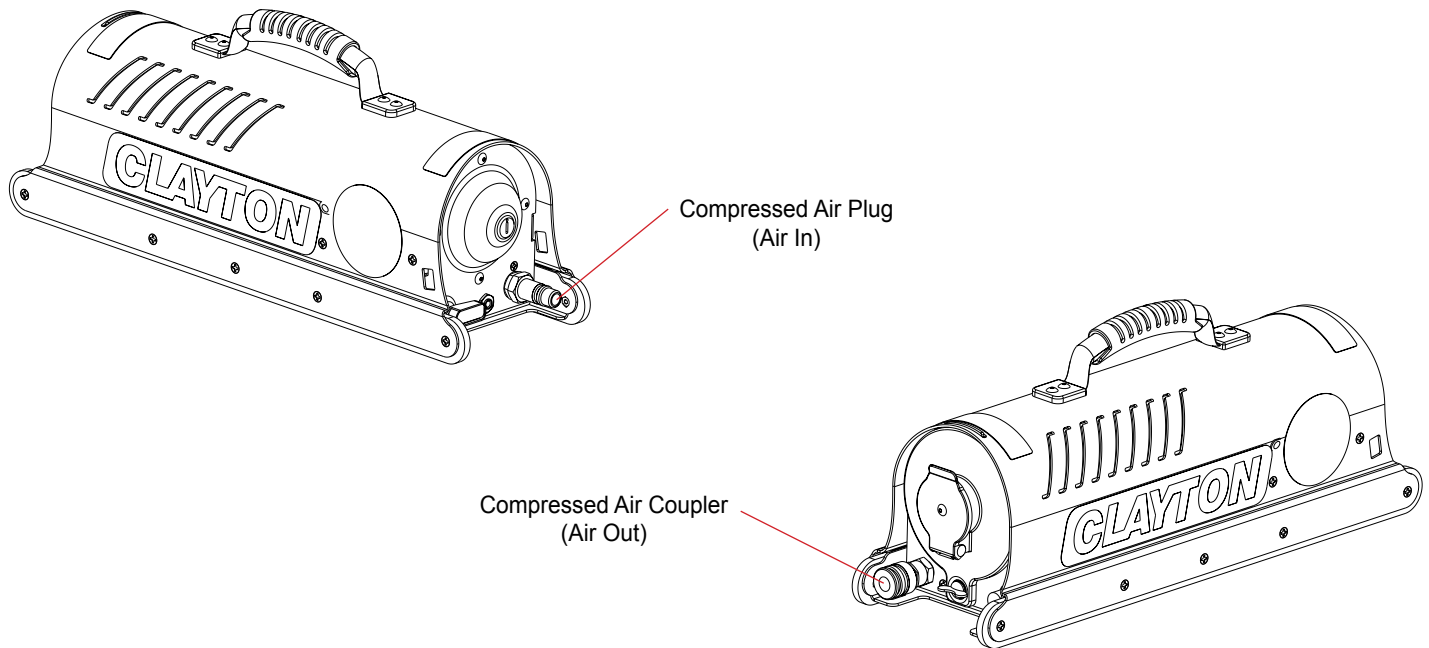

DYNAMIC POWER CONTROL

1. Adjusting the DPC (Dynamic Power Control)

- Vacuum power and compressed air consumption can be adjusted by turning the DPC with a large flat head screwdriver
- The DPC rotates 1-1/2 turns from fully closed to fully open
- Do not force the rotation past these limits

- Rotate the DPC clockwise to the fully closed position
- Rotate the DPC counterclockwise 1 full turn to the factory setting

- To increase vacuum power and compressed air consumption turn the DPC counter-clockwise up to an additional 1/2 turn
- To decrease vacuum power and compressed air consumption turn the DPC clockwise up to an additional 1/2 turn

DIFFERENTIAL PRESSURE GAUGE

Principle of Operation

As the bag filter is loaded with debris, the debris restricts airflow thru the bag. This restriction increases the differential pressure which is displayed on the Gauge located on the bottom of the Hornet Vacuum. This can help determine when to change the bag filter.

Clayton recommends that the bag filter be changed when it is approximately 80% full by volume. Keep in mind that if the debris is something like fine powder it will create more restriction and therefore a greater differential pressure than something like rivet stems.

The differential pressure gauge has a range of 0 to -100. We recommend that each customer test the hornet in situ to determine their gauge readings for both a clean bag filter and a bag filter 80% full using the procedure below.

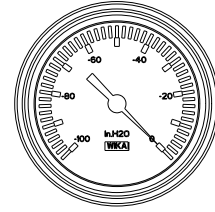

1. Testing the Differential Pressure

Each customer should tailor their differential pressure testing schedule based on how quickly the bag filter will typically reach capacity in their specific environment.

2. Attach the Compressed Air line

Clayton EXP compressed air lines are conductive and provide compressed air to power the vacuum and as a drain for static buildup. *This equipment is only validated for dust ignition proof operation when used with this air line*

- Ensure that the compressed air valve on the vacuum is in the off position
- Connect the compressed air line to a compressed air source
- Connect the compressed air line to the compressed air plug on the vacuum

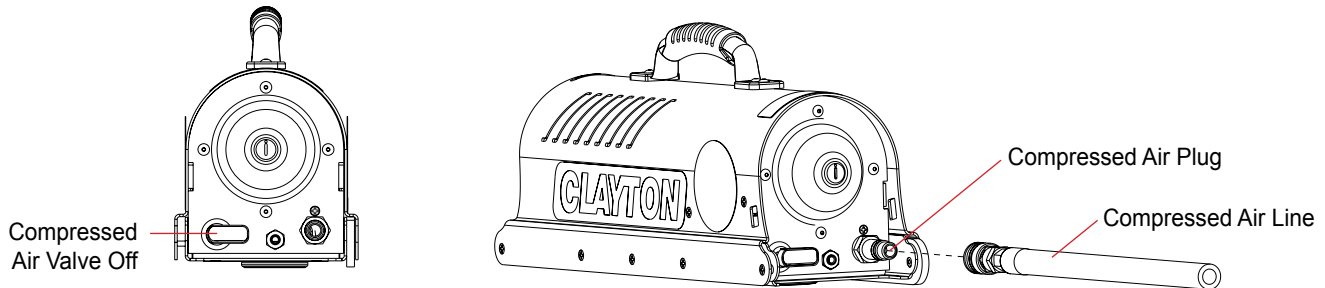

3. Activating the Vacuum

- Rotate the compressed air valve on the vacuum
- 90 degrees counterclockwise to start compressed air flowing and activate the vacuum

4. Reading the Gauge

- Once the vacuum is running, lay the vacuum on its side so that the gauge is visible
- Hold the inlet port open with your hand (do not insert a hose)
- Read the gauge
- Close the inlet port
- Deactivate the vacuum

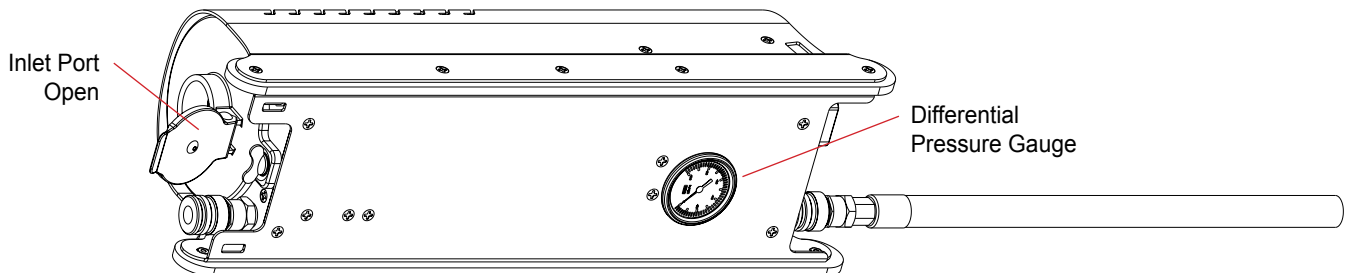
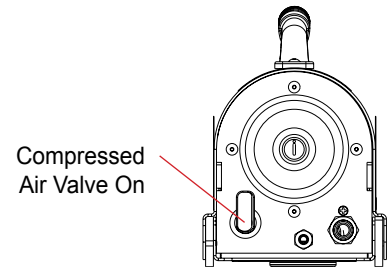

BEFORE EACH USE

1. Visually inspect vacuum to ensure that no parts are missing or damaged

2. Install a new Filter Bag if required

- See the Bag Filter Change section of this document

3. BONDING AND GROUNDING

- This is required only if the vacuum will be used in the presence of combustible dust
- To ensure safe operation, all conductive parts of the vacuum should be electrically bonded

Use the included continuity tester; check the vacuum for bonding before each use

- Connect the alligator clip of the continuity tester to the 1/2 inch compressed air plug (see below)
- Using the continuity test probe, touch the designated points on the bonding diagram to test for continuity

▲ Warning: Do not use this equipment in a classified environment if any test points do NOT pass the continuity test.

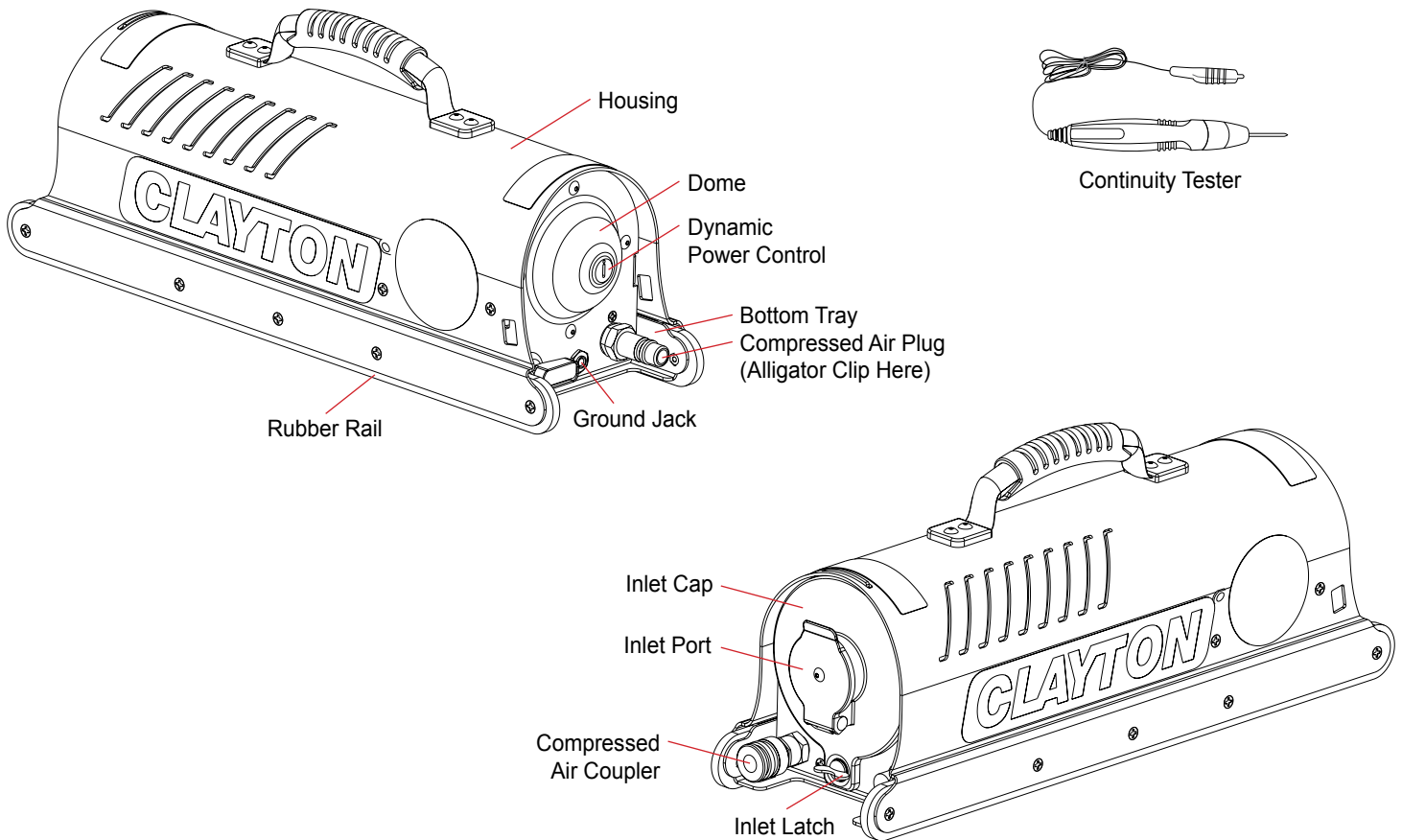

BEFORE EACH USE

4. Attach the Grounding Cable

- This is required only if the vacuum will be used in the presence of combustible dust
- The grounding cable included should be plugged into the grounding jack and clamped to either the work piece or the same grounding point as the work piece.

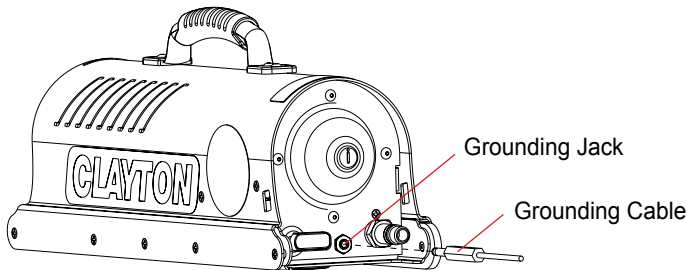

5. Attach the Compressed Air Line

Clayton EXP compressed airlines are conductive and provide compressed air to power the vacuum and as a drain for static buildup
This equipment is only validated for dust ignition proof operation when used with this airline

- Ensure that the compressed air valve on the vacuum is in the off position
- Connect the compressed airline to a compressed air source
- Connect the compressed airline to the compressed air plug on the vacuum

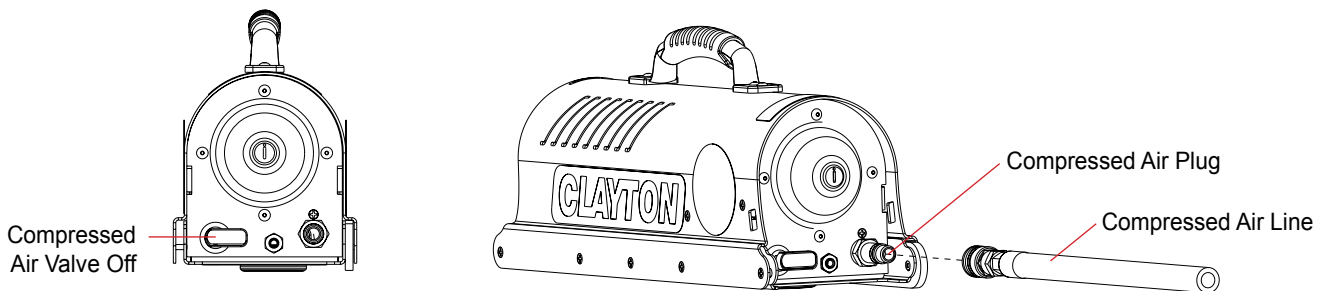

6. Attach the Vacuum Hose

Clayton EXP vacuum hoses are conductive and provide a drain for static buildup

This equipment is only validated for dust ignition proof operation when used with these vacuum hoses

Vacuum Hose only

- Open the Vacuum Inlet
- Insert the metal sleeve of the vacuum hose into the inlet on the vacuum

Combination Air/Vac Hose

- Open the Vacuum Inlet
- Insert the metal sleeve of the vacuum hose into the inlet on the vacuum
- Connect the compressed airline to the compressed air coupler on the vacuum

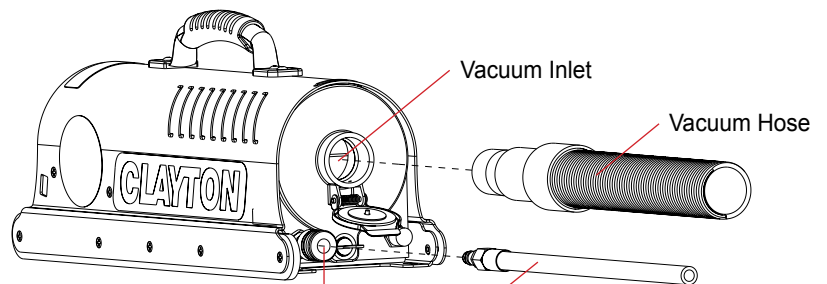

7. Activating the Vacuum

Rotate the compressed air valve on the vacuum 90 degrees counter-clockwise to start compressed air flowing and activate the vacuum

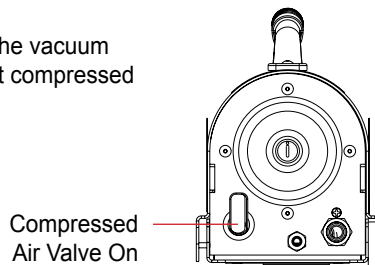

BAG FILTER CHANGE

If this vacuum is used to collect hazardous material, please use the Safe Filter Change section

The bag filter should be replaced when $\frac{3}{4}$ full

1. Safe the Vacuum

- Move the vacuum to a non rated area
- Disconnect the compressed air source from the vacuum
- Disconnect the grounding cable
- Disconnect the vacuum hose

2. Remove the Inlet Cap and Bag

- Rotate the inlet latch 1/4 turn counter clockwise
- Grasp the inlet cap and remove by tilting the bottom out and then pulling down

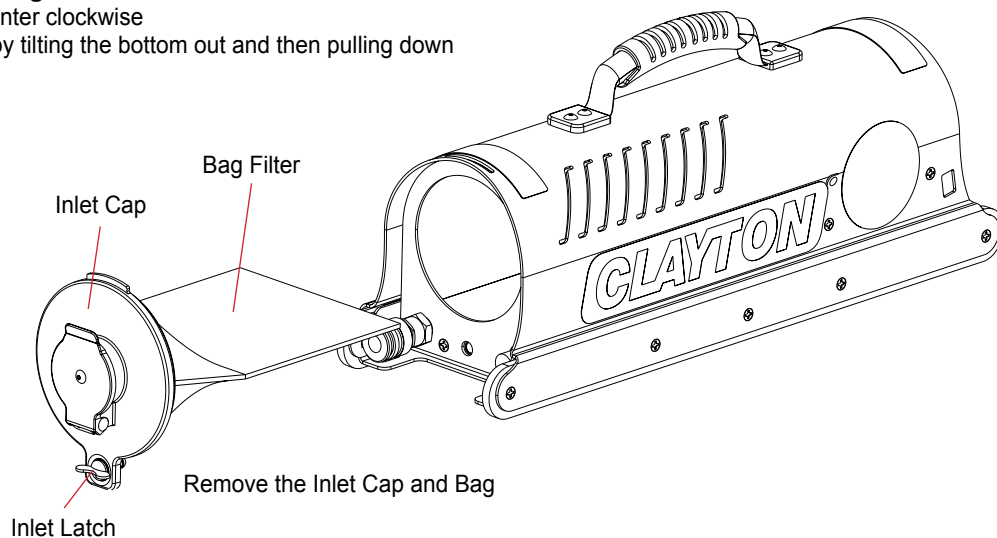

3. Remove the Filter Bag from the Inlet Cap

- Hold the Inlet Cap in your left hand
- Grasp the bag with your right hand and pull while twisting
- Dispose of the bag according to your company policy

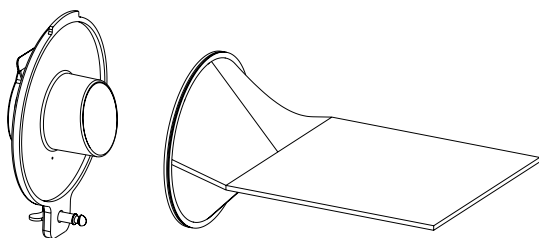

Remove the Filter Bag from Inlet Cap

4. Install a Filter Bag

- Unfold a new Filter Bag
- Push the inlet tube into the hole on the cardboard collar of the Filter Bag
- Ensure the cardboard collar is flush against the inside of the inlet cover

5. Reinstall the Inlet Cap

- Replace the Inlet Cap
- Press the latch in and rotate 1/4 turn clockwise to lock

SAFE FILTER CHANGE

When used to collect hazardous material, personal protective equipment should be used when opening the vacuum
The bag filter should be replaced when $\frac{3}{4}$ full

1. Attach the Grounding Cable

- This is required only if the vacuum will be used in the presence of combustible dust
- The grounding cable included should be plugged into the grounding jack and clamped to either the work piece or the same grounding point as the work piece

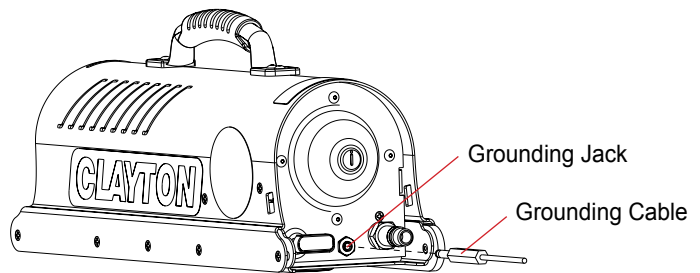

2. Attach the Compressed Air Line

Clayton EXP compressed airlines are conductive and provide compressed air to power the vacuum and as a drain for static buildup
This equipment is only validated for dust ignition proof operation when used with this airline

- Ensure that the compressed air valve on the vacuum is in the off position
- Connect the compressed airline to a compressed air source
- Connect the compressed airline to the compressed air plug on the vacuum

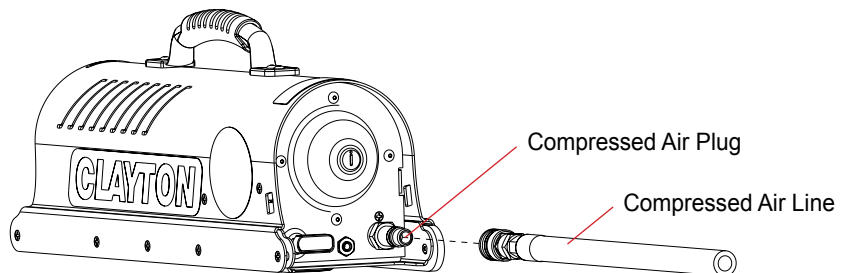
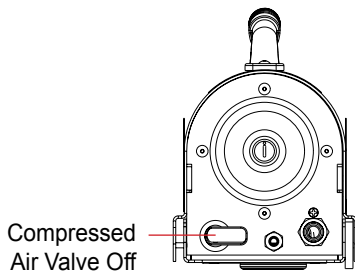

3. Activate the Vacuum

- Rotate the compressed air valve on the vacuum 90 degrees counter-clockwise to start compressed air flowing and activate the vacuum

4. Pull the Inlet Cap partially off the vacuum

- Rotate the inlet latch 1/4 turn counter clockwise
- Open the inlet and hold it open to relieve the suction
- Grasp the inlet cap and pull while tilting the bottom down until the top of the cap is disengaged from the vacuum housing
- Be sure that the bag filter remains in the vacuum until the cap is completely removed
- Continue to wiggle the cap off the vacuum and out of the bag
- Use your finger to hold the bag in the vacuum if needed

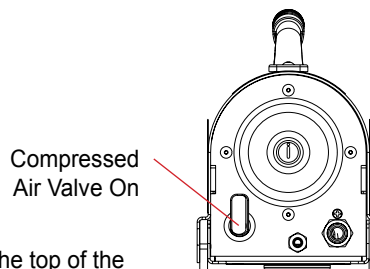

5. Remove the Bag Filter with a Disposal Bag

- Turn a Disposal Bag inside out over your right hand
- With your bagged hand, grasp the opening in the Bag Filter
- Pull the Bag Filter out of the vacuum while using your left hand to wrap the Disposal Bag around the Bag Filter
- Keep the open end of the Disposal Bag as close to the vacuum intake as possible
- Once the Bag Filter is completely inside the Disposal Bag, Seal the Disposal Bag
- Dispose of the Bag Filter according to your company policy

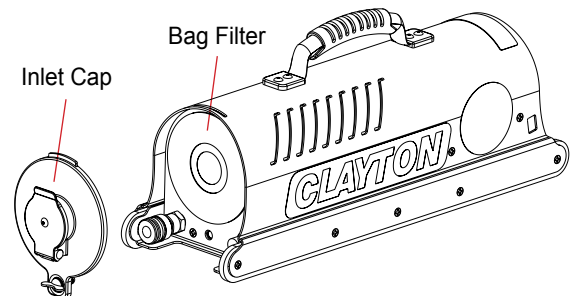

SAFE FILTER CHANGE

6. Install a Filter Bag

- Unfold a new Filter Bag
- Push the inlet tube into the hole on the cardboard collar of the Filter Bag
- Ensure the cardboard collar is flush against the inside of the inlet cover

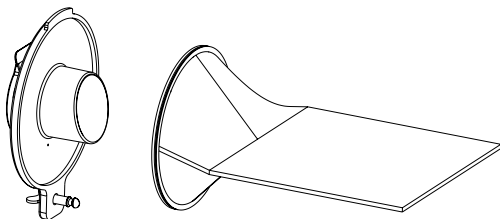

Install a Filter Bag

7. Reinstall the Inlet Cap

- Replace the Inlet Cap
- Press the latch in and rotate 1/4 turn clockwise to lock

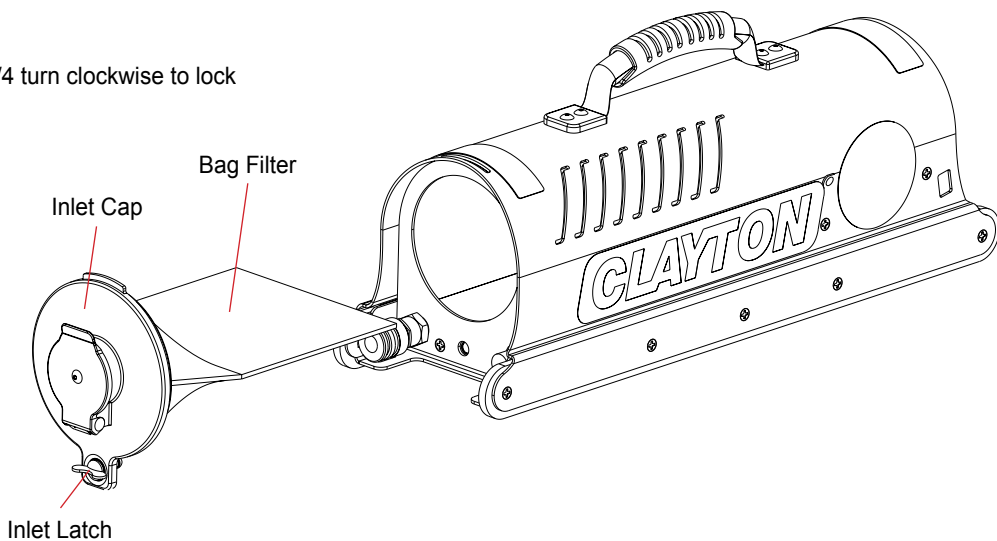

HEPA FILTER CHANGE

If this vacuum is used to collect hazardous material, personal protective equipment should be used when opening the vacuum. The HEPA filter should be replaced when it is damaged, clogged, or when the HEPA timer card has reached 12 months.

1. Safe the Vacuum

- Move the vacuum to a non rated area
- Disconnect the compressed air source from the vacuum
- Disconnect the grounding cable
- Disconnect the vacuum hose

2. Remove the Inlet Cap

- Rotate the inlet latch 1/4 turn counterclockwise
- Grasp the inlet cap and remove by tilting the bottom out and then pulling down

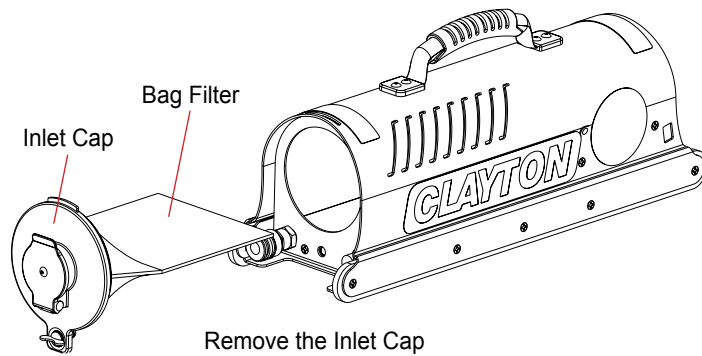

3. Unbox a new HEPA Filter

- Remove the Clayton HEPA timer card from the box and set aside
- Remove the HEPA filter from the box and unwrap

4. Remove the HEPA Filter

- Using a 3/4 inch socket wrench and an extension unscrew the HEPA filter counterclockwise
- Dispose of the HEPA filter according to your company policy

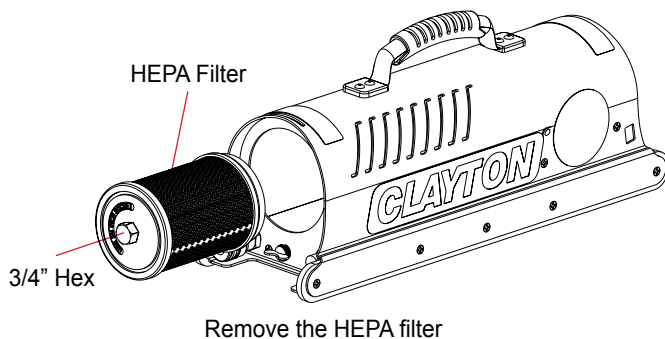

5. Install a new HEPA Filter

- Using a 3/4 inch 6 point socket wrench and an extension
- Screw the new HEPA filter onto the threaded nipple until it hard stops or reaches 46 in/lbs of torque

6. Reinstall the Inlet Cap

- Replace the inlet cap
- Press the latch in and rotate 1/4 turn clockwise to lock

7. Activate the HEPA Filter Timer

- Remove the old HEPA timer card from the top handle of the vacuum
- Attach the new HEPA timer card with a zip tie (included) to the top handle of the vacuum
- Follow the directions on timer card to activate

BACKPACK HARNESS

Attaching the Backpack Harness

- The Backpack Harness clips to four points on the Hornet Vacuum
- With the Hornet held vertically the Inlet Port should be facing up
- Attach clips "A" on the harness to the two slots as shown
- Attach clips "C" on the harness to the slots as shown
- Unclip sternum strap "B" and slip your arms thru the harness as you would a backpack
- Adjust and clip the sternum strap
- Adjust the harness by pulling down on straps "D"

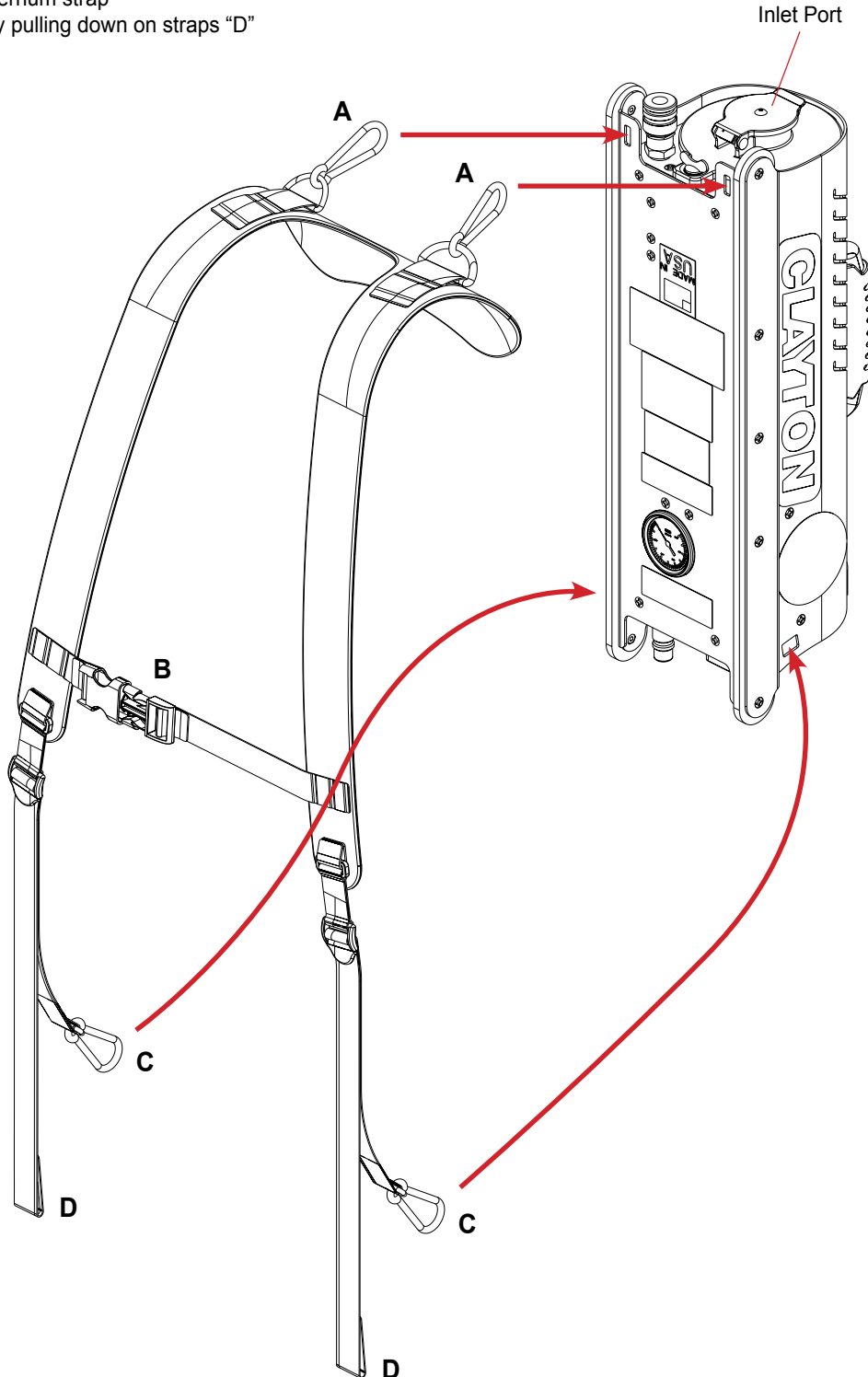

ILLUSTRATED PARTS BREAKDOWN

Seq	Item No	Description
1	500-401-02A	Rear Bulkhead Plate Without Dome
2	500-401-02B	Rear Bulkhead Bumpout, Electroless Nickel Plated
3	900-011	Grounding Jack For Vacs-Winchester
4	911-05G12	Grommet, 5/16 ID, 3/4 Hole, 1in OD
5	918-04SL	FTG, 1/4 Street Elbow, Brass
6	918-08C	HEX Coupler, 1/2 X 1/2 FNPT
7	918-08HN	HEX Nipple, 1/2in Brass, Length 1.5in
8	922-T.25GN	1/4in OD. Nylon Tubing Green
9	922-T.50NGE	Tubing, 1/2 Polyethylene, Orange
10	924-08FL08-2	Valve Shaft, Extension
11	924-08FL08-3	Valve Handle, Plastic
12	924-08FL08-5	Valve Handle Cover Blue Plastic
13	924-08L	Ball Valve, 1/2 RT Angle
14	925-P08R120-01	Gauge Pressure 1/2in 0-120 PSI Panel Mount
15	925-V32R100-01	Gauge Vacuum 2in 0-100 in/H2O Panel Mount
16	927-04L-04F	FTG, 1/4 X 1/4 Elbow, PC TO FNPT
17	927-04MA-02	1/4 PC X 1/8 MNPT Adapter
18	927-08L-08	FTG Elbow 1/2 PC TO 1/2 MNPT
19	927-08MA-08	FTG, 1/2TX1/2P Male Conn
20	940-011	Fitting Coupler 1/4in HiFlow x 1/4 MNPT
21	942-04040808	Hornet Manifold
22	942-0808	Hornet Coupler
23	951-0183	DZUS Receptacle
24	NE08321115-HNSZ	Nut 8-32 X 11/32 Lock Nylon SS
25	RE0614-PDSSS-Z	Rivet Blind 3/16 x 0.438 Open SS (.126-.25)
26	SE044007-PPSM-Z	Screw, SS, PH, 4-40 X 7/16
27	SE063205-PFSM-Z	Screw, FH100, SS, 6-32 X 5/16
28	SE083204-PFSM-Z	Screw, 8-32 X 1/4, FH100, SS
29	SE083207-PFSM-Z	Screw, FH100, 8-32 X 7/16, SS
30	SE083212-PPSM-Z	Screw, PPH, .164-32 X .750 Long
31	WE04050000-RZSZ	No 4 Washer, MS-15795-804

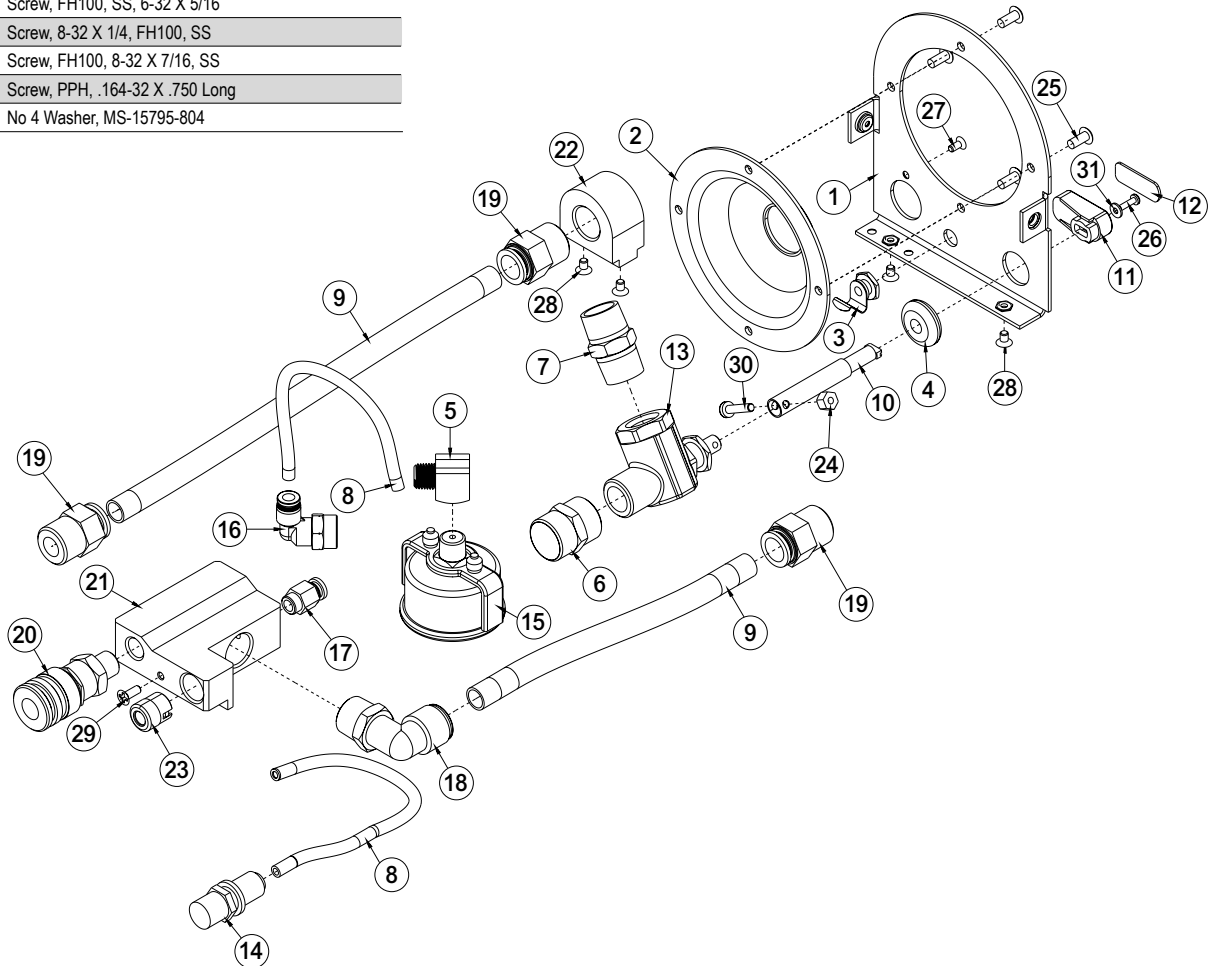

ILLUSTRATED PARTS BREAKDOWN

Seq	Item No	Description
1	500-401-01	Hornet Tray
2	500-401-06	Hornet Cover
3	911-075	Conductive Rubber Rail, Hornet Foot
4	930-027	Handle, Carry, Flex Rubber
5	RE0614-PDATB-Z	Rivet Blind 3/16 x 0.438 Open Alum Blk (.063-.25)
6	SE083204-PFSM-Z	Screw, 8-32 X 1/4, FH100, SS
7	SE083207-PFSM-Z	Screw, FH100, 8-32 X 7/16, SS

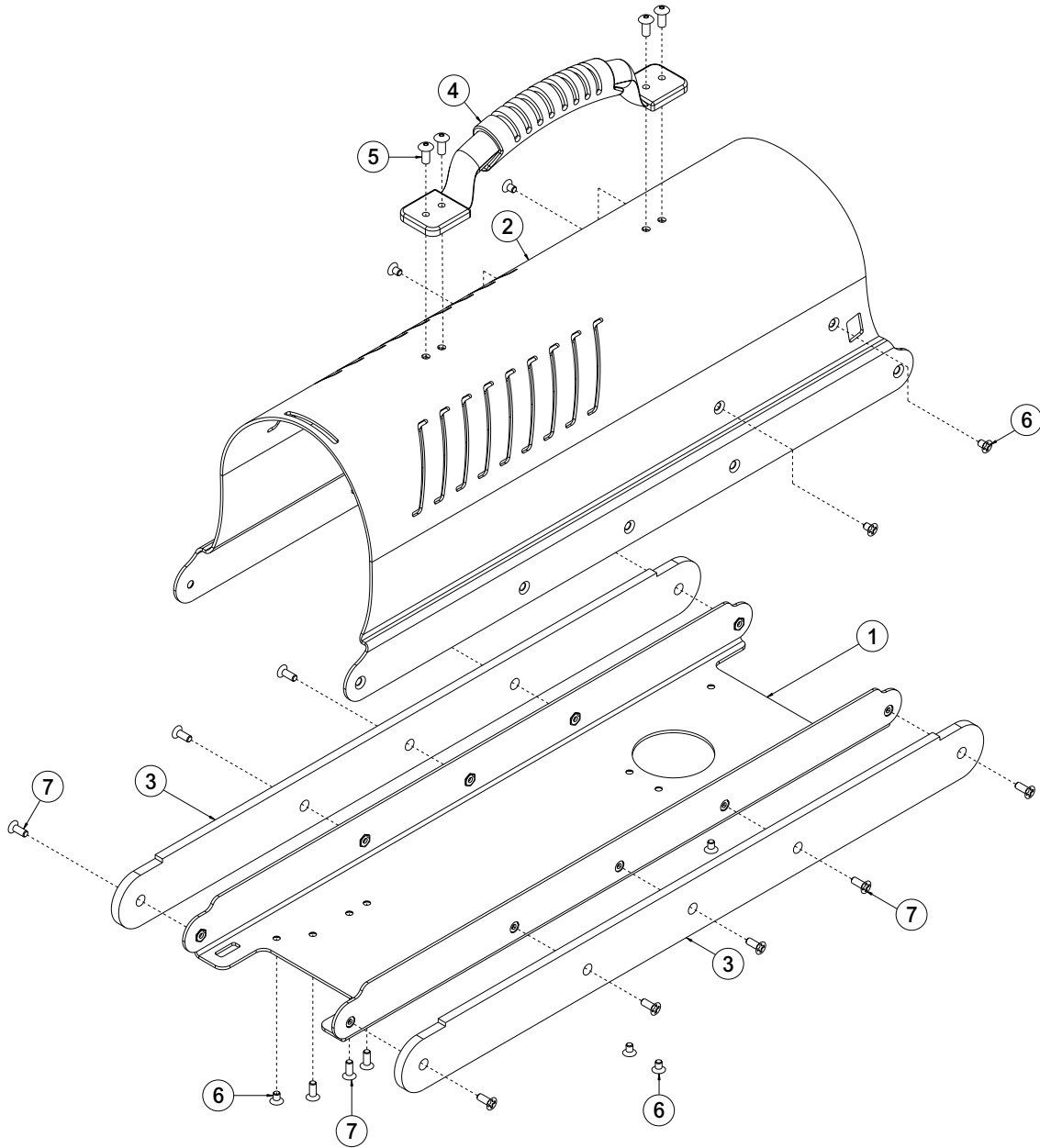

ILLUSTRATED PARTS BREAKDOWN

Seq	Item No	Description
1	627-516H	HEPA Filter for Hornet / Scorpion
2	690-A0031	Filter Bag, Super Hornet, 10 PK
3	923-A007	Cast Valve Assembly For Superhornet
4	951-0180	DZUS Fastener Quarter Turn SS
5	951-0181	DZUS Spring
6	951-0182	DZUS Washer
7	951-0184	DZUS Wear Washer, Black

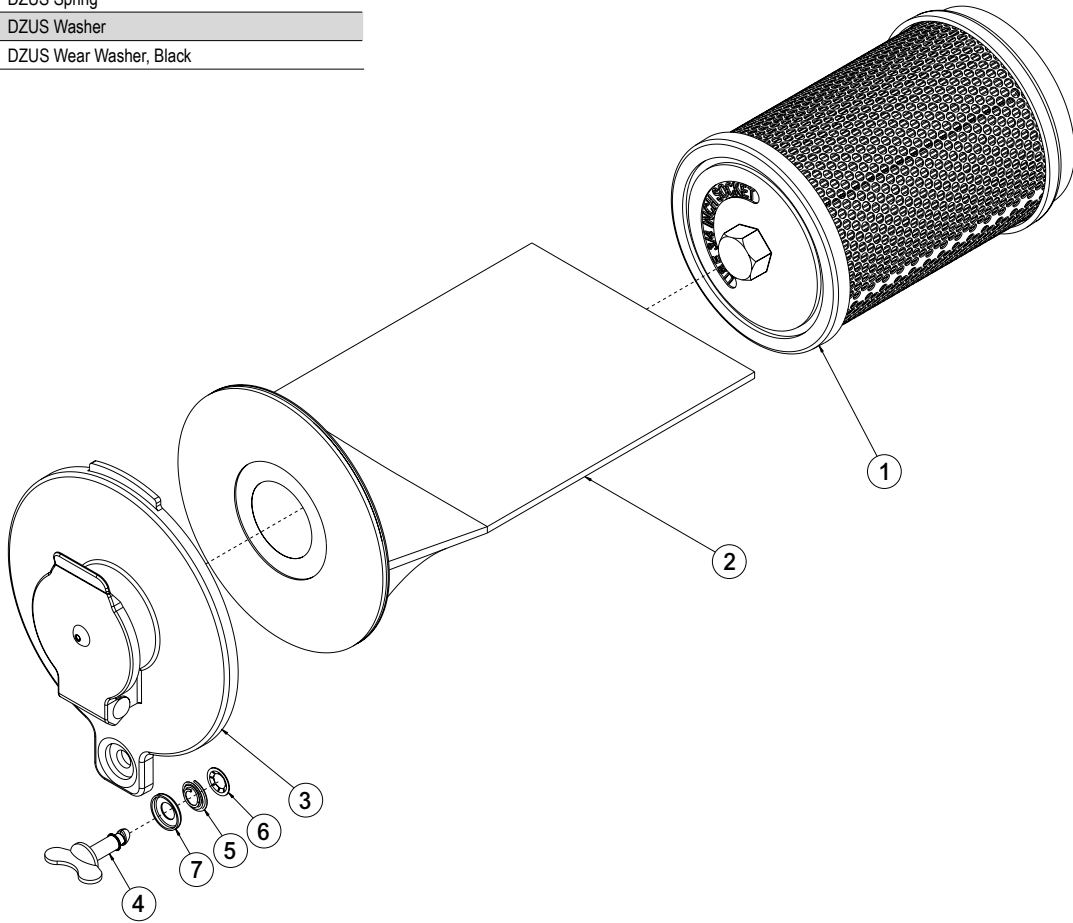

ILLUSTRATED PARTS BREAKDOWN

Seq	Item No	Description
1	500-401-08	Flange Motor Adjustment For Superhornet
2	500-401-A04	Hornet Tank Assembly
3	600-021	Air Motor Super Hornet Nickel Plated
4	601-023	Hornet Filter adapter Nickel Plated Aluminum
5	911-016	Motor gasket for Hornet
6	911-12G22	Grommet, 3/4 x 1 3/8
7	911-802	Foam Muffler, Super Hornet
8	927-04L-1032M	FTG Elbow 10-32 TO 1/4 PC
9	FE103212-HZSM-Z	HEX Standoff, 10-32 MF X 3/4in SS
10	SE103206-PFSM-Z	100 DEG FHS, .190-32 X .375in Long
11	SE103210-PFSM-Z	Screw, FH100, SS, 1032 X .625

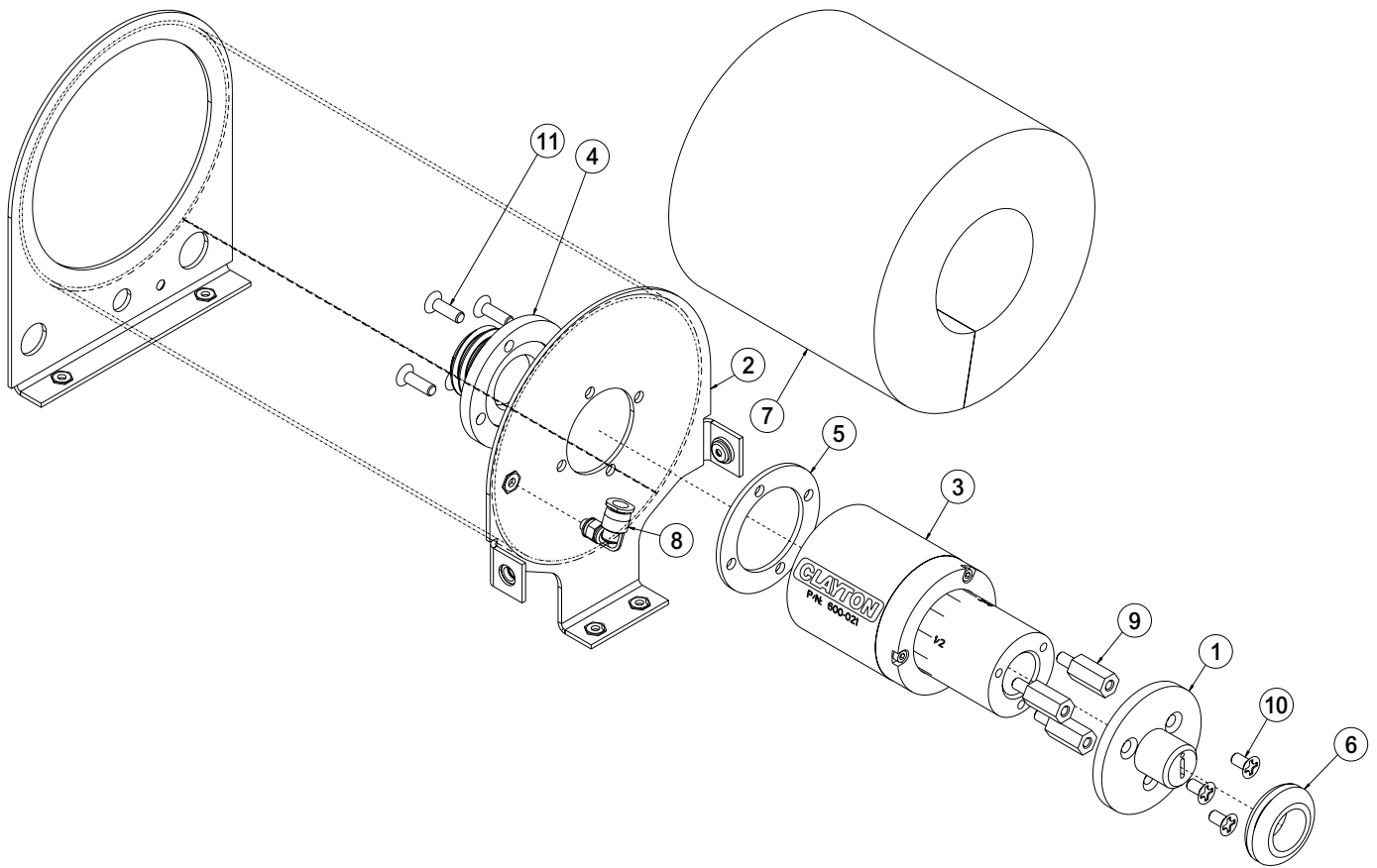

LIMITED LIFETIME WARRANTY TERMS AND CONDITIONS

Warranty Terms

Clayton Associates, Inc. guarantees its manufactured products against defects in materials or workmanship and will either repair or replace all parts that prove defective under normal use during the lifetime of the products. The warranty period shall commence from the date of paid invoice.

This warranty does not cover (a) repairs due to normal wear, accident, neglect, misuse, or use other than as indicated in the instruction booklet (b) products manufactured by third parties and distributed by Clayton (c) wear items such as bearings, rotor blades, regulators, valve stems, levers, shrouds, guards, O-rings, seals, gaskets, motor brushes, and other wearable parts.

Repair within the Continental US

During the first 90 days of the warranty period, Clayton will provide parts and labor to the customer's site at no charge or pay freight costs associated with returning the products for repair to a Clayton selected service location and repair the product at no charge. Clayton personnel will determine the best way to repair the product.

Past 90 days, Clayton will provide parts to the customer's site at no charge or the customer may ship the product to a Clayton selected service location at customer's expense and Clayton will repair the product at no charge and provide return shipping.

Repair Outside the Continental US

Clayton will provide parts to the customer's site at no charge or the customer may ship the product to a Clayton selected service location at customer's expense and Clayton will repair the product at no charge and provide return shipping.

Limitation of Liability

Clayton shall not in any event be liable for any damages, loss of production time or profits, whether based on contract, warranty, negligence, strict liability or otherwise, including without limitation any consequential, incidental or special damages, arising with respect to the equipment or its failure to operate.

Clayton Associates, Inc. makes no other warranty or representation of any kind, except that of title, and all other warranties, express or implied, including warranties of merchantability or fitness for any particular purpose, are hereby expressly disclaimed.

EC DECLARATION OF CONFORMITY



Clayton Associates, Inc. of 1650 Oak Street, Lakewood New Jersey 08701 U.S.A. declare on our own responsibility that the following equipment:

Pneumatic HEPA Filtered Vacuum Cleaner and Accessories for Dry Recovery

- Model 500-400 bearing this marking **CE Ex II 3 D T85°C**
- Individually and when comprised in kits with the prefixes **ACE-XXX** and **ACE-XXXX**
- With serial numbers ranging from **HN0000001** through **HN9999999**

Are designed and manufactured in compliance with the essential requirements and other relevant provisions of the following applicable directives:

- **Machinery Directive 2006/42/EC**
- **ATEX Directive 2014/34/EU**

Compliance has been obtained by application of the following standards:

- **EN ISO 12100:2010-11**
- **EN ISO 80079-36:2016**
- **EN ISO 80079-37:2016**
- **EN 60079-0:2012/A11:2013**
- **EN ISO 4414:2010 excluding references to Unintended Pressures section 5.2.2**
- **EN 60335-2-69:2012 specifically Annex AA: Requirements for vacuum cleaners and dust extractors for the collection of hazardous dusts**

The legally authorized entity, established in the EU for retaining the ATEX technical documentation and compiling the technical file is ExVeritas Limited, Unit 16-18, Abenbury Way, Wrexham Industrial Estate, Wrexham, LL13 9UZ, United Kingdom.

File Number: 18FILE0344

Subject to use for the purpose for which it was designed in accordance with relevant standards and with the manufacturer's recommendations. We hereby declare that the equipment specified above conforms to the listed Directives and Standards.

Brad Clayton
President
Clayton Associates, Inc.

Place of Issue: Lakewood, New Jersey, USA November 23, 2018



Clayton products are proudly made in the USA

