

GB456A

INSTALLATION TOOL

GAGE BILT
I N N O V A T I V E
R I V E T & L O C K B O L T T O O L S

44766 Centre Ct. Clinton Twp. MI 48038 USA

+1 586. 226.1500

+1 586. 226.1505

solutions@gagebilt.com

www.gagebilt.com

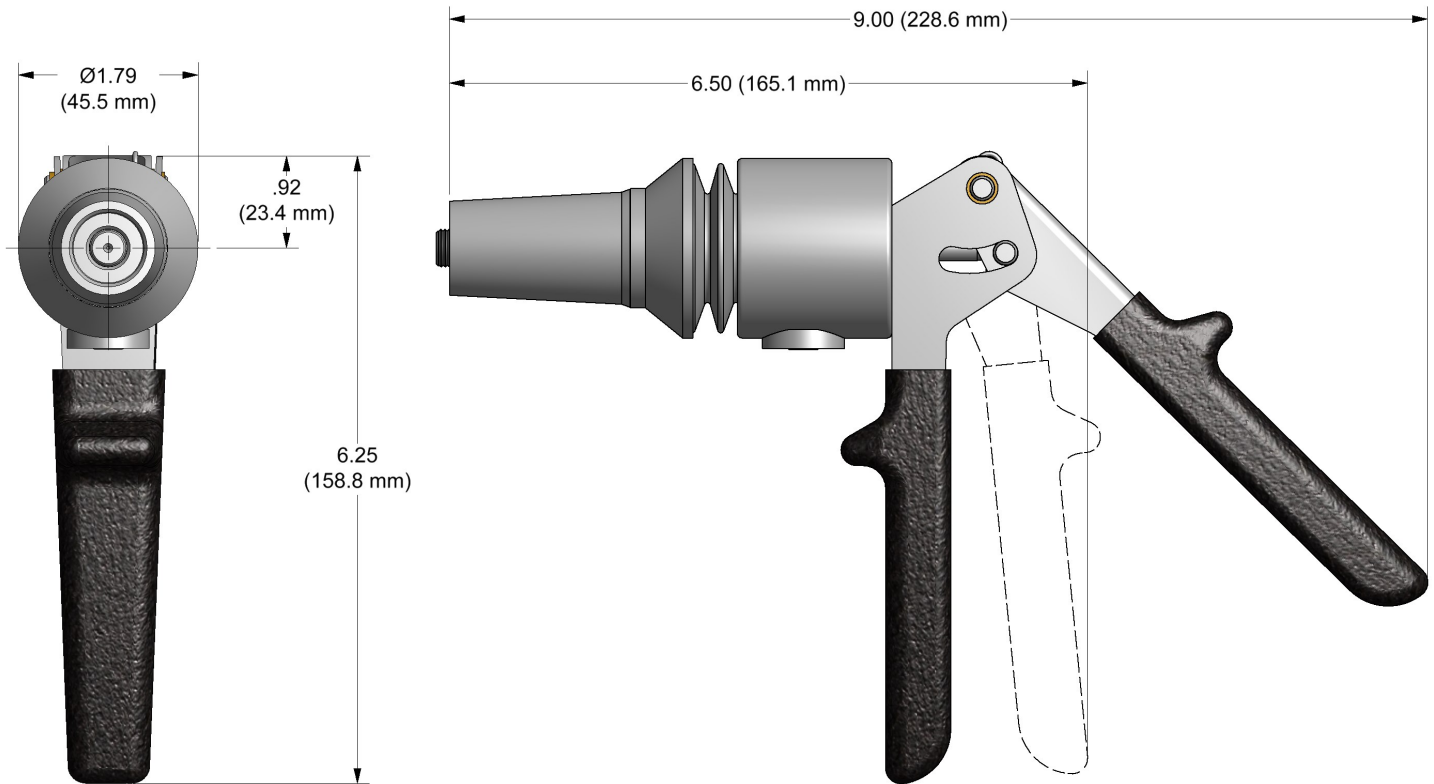

DESCRIPTION:

The GB456A is a hydraulic hand riveter designed specifically for the most efficient installation of all 1/8", 5/32", 3/16" and 1/4" Ø Cherrymax®, Allmax®, & Huckmax® rivets. It weighs 20oz. (.57 kg) and is 6-1/4" high x 6" long x 1-3/4" wide without a nose assembly. The GB456A has a .565 (14.35 mm) minimum stroke and a rated pull load of 3,500 lbs. (15.57 kN).

Gage Bilt Powermax nose assemblies, part numbers 456MAX-701-17, 456MAX-704-35, 456MAX-749-35, 456MAX-704-54RA & 456MAX-704-43OS, fit directly on this tool: See Nose Assembly Selection Chart for other applications.





GB456A NOSE ASSEMBLY SELECTION CHART

FASTENER	DIAMETER	STRAIGHT	RIGHT ANGLE (2)	OFFSET
CHERRYMAX®, CHERRYMAX® 'AB', MBC® LOCK CREATOR BACR15FR/FP, BACR15GF/GK, NAS1900 S & U SERIES BLIND RIVET WITH DRIVE WASHER	1/8 5/32 3/16	456MAX-701-17 (1) 456MAX-704-35 (1) 456MAX-749-35 (1,3)	456MAX-704-54RA (1,2)	456MAX-704-43OS (1)
NUT PLATE RIVETS MS20600 SERIES CCR244/264/274 MS/9SP/PT BACR15CC/CF/DA/DR	3/32 1/8 5/32 3/16	3C-715B-43 (4) 4C-715B-43 (4) 5C-715B-43 (4) 6C-715B-43 (4)	3C-704-54RA (2) 4C-704-54RA (2) 5C-704-54RA (2) 6C-704-54RA (2)	3C-704A-40OS 4C-704A-40OS 5C-704A-40OS 6C-704A-40OS
'A' CODE NAS1398A NAS1399A	3/32 1/8 5/32 3/16	3A-715B-43 (4) 4A-715B-43 (4) 5A-715B-43 (4) 6A-715B-43 (4)	3A-704-54RA (2) 4A-704-54RA (2) 5A-704-54RA (2) 6A-704-54RA (2)	3A-704A-40OS 4A-704A-40OS 5A-704A-40OS 6A-704A-40OS
GROUND STUD M83454 BACS53B1EA1/2	8/32 10/32	GS8-715B-43 (4) GS10-715B-43 (4)		

CHERRYMAX® AND MBC® ARE REGISTERED TRADEMARK OF CHERRY AEROSPACE FASTENERS.

GAGE BILT CERTIFIES THE GB456A WILL INSTALL THE ABOVE FASTENERS

- | |
|--|
| 1) INSTALLS 1/8", 5/32", AND 3/16" DIAMETERS |
| 2) RIGHT ANGLE NOSE ASSEMBLIES MAY REQUIRE MORE THAN ONE PULL. |
| 3) FRONT END EJECTING NOSE ASSEMBLY. |
| 4) REQUIRES 704001 ADAPTER |

NOTE: THE LAST 2 DIGITS OF THE NOSE ASSEMBLY REPRESENTS THE LENGTH THE NOSE EXTENDS FROM THE TOOL I.E. -20 = 2.0 INCHES

Rev. 1/20

Right Angle

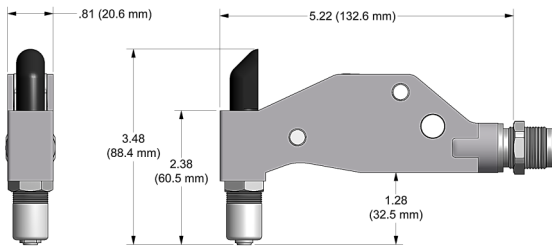

Straight

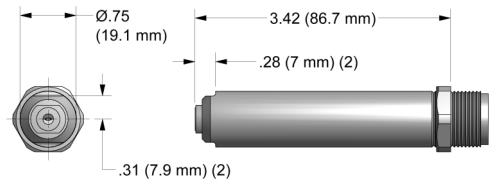

Offset

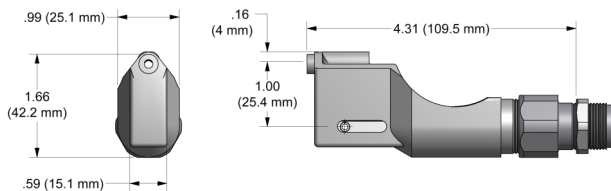

Riveter Kits Available

Contact Gage Bilt for more information.

