

GB704

PNEUDRAULIC INSTALLATION TOOL SERIES

GAGE BILT

RIVET & LOCKBOLT TOOLS

44766 Centre Ct. Clinton Twp. MI 48038 USA

+1 586. 226.1500

+1 586. 226.1505

solutions@gagebilt.com

www.gagebilt.com

GB704

Stroke - .540" (13.72 mm)
Tool weight - 4.30 lbs. (1.95 kg)
Pull load - 3,300 (14.68 kN)

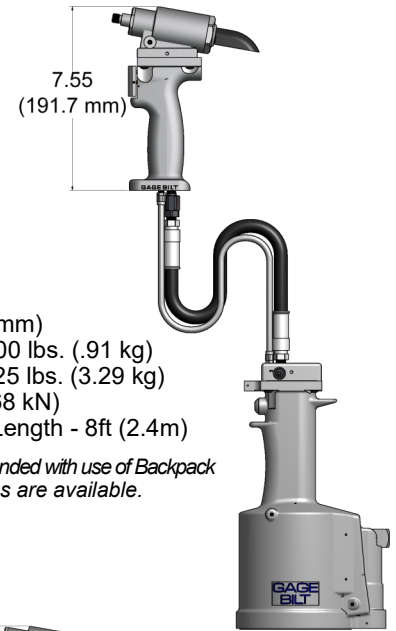
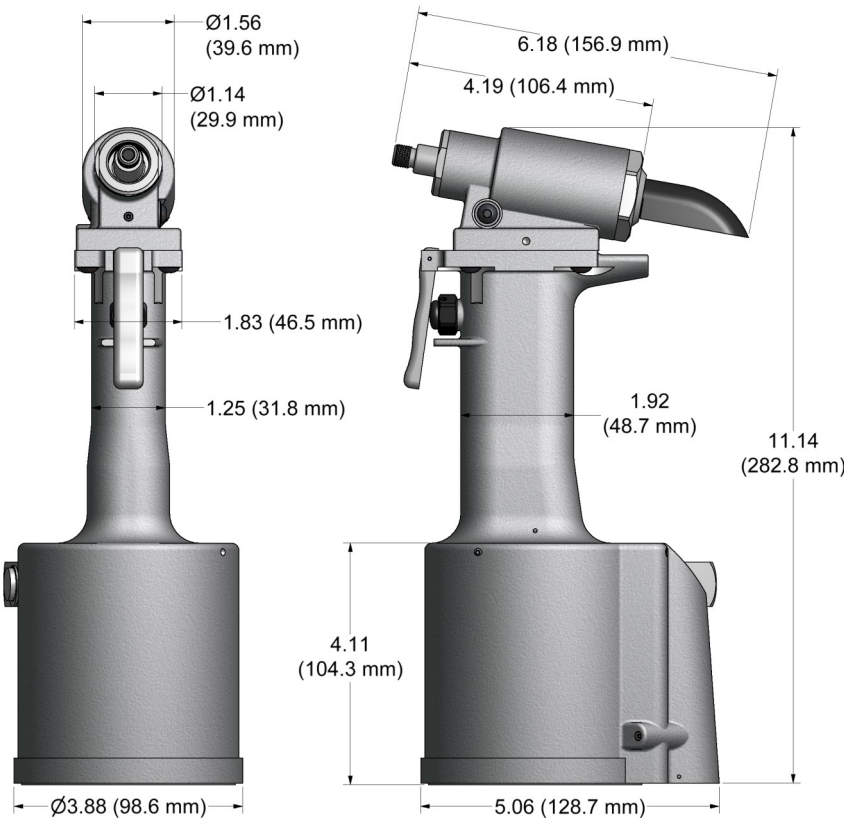

GB704SH

Stroke - .600" (15.24 mm)
Hand held weight - 2.00 lbs. (.91 kg)
Entire tool weight - 7.25 lbs. (3.29 kg)
Pull load - 3,300 (14.68 kN)
Standard Hyd. Hose Length - 8ft (2.4m)

*5ft Hyd. Hoses are recommended with use of Backpack
Additional custom lengths are available.*

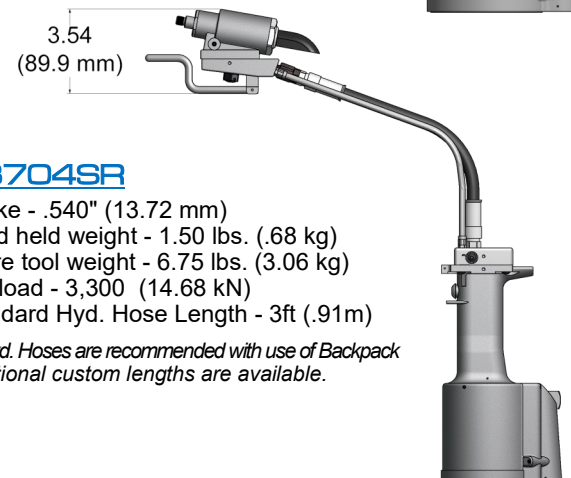

GB704SR

Stroke - .540" (13.72 mm)
Hand held weight - 1.50 lbs. (.68 kg)
Entire tool weight - 6.75 lbs. (3.06 kg)
Pull load - 3,300 (14.68 kN)
Standard Hyd. Hose Length - 3ft (.91m)

*5ft Hyd. Hoses are recommended with use of Backpack
Additional custom lengths are available.*

The **GB704** series are pneumatic-hydraulic installation tools, designed specifically for the efficient installation of blind rivets. They can be operated in any position and have a rated pull load of 3,300 (14.68 kN) pounds with 90 psi (6.2 bar) air pressure at the air inlet.

The **GB704SH** and **GB704SR** split handle installation tools offer a unique "split" system providing the operator with an ergonomic tool with reduced hand held weight. The **GB704SH** comes with 8 feet (2.4 m) of hose and the **GB704SR** comes with 3 feet (.91 m) of hose. Use with our "NEW" Split-System Backpacks to increase user mobility, ergonomics and productivity. Contact GAGE BILT for more information.

The **GB704** series tools operate on 90 to 100 psi. (6.2-6.9 bar) of air pressure, with 90 psi. (6.2 bar) providing the maximum efficiency. At 90 psi. (6.2 bar) of air pressure, the **GB704** series does not exceed 81.5 dB(A) and consumes .16 SCF/cycle (4.53 L/cycle). The air inlet is provided with 1/4-18 female pipe thread to accept the users air hose fitting.

**NOSE ASSEMBLIES ARE NOT FURNISHED WITH
TOOL AND MUST BE ORDERED SEPARATELY**





GB704 ACCESSORIES

Approved for use on Gage Bilt CE installation tools and/or other manufacturer's CE approved tools of similar design. (Sold Separately)

ACCESSORIES (Sold Separately)

Catcher Bag-Stem
#704214
(Sold Separately)



Air Bleeder Assy
#704153
(Sold Separately)



Grip Gage #GB105093

For NAS LOCKBOLTS and blind fasteners
(Sold Separately)



Grip Gage #269G3

For CHERRYMAX® and CHERRYLOCK® rivets
(Sold Separately)



SPLIT-SYSTEM TOOL BACKPACKS

- Backpack fits any split-system tool
- Reduces weight of tool by up to 70%
- Reduces User Fatigue
- Increases Productivity
- Increases User Mobility
- Ergonomic
- Comfortable

INSIDE VIEW

OPTIONAL Vacuum System for FOD Control

NOSE ASSEMBLY CHART (Sold Separately)

STRAIGHT
(Sold Separately)

RIGHT ANGLE
(Sold Separately)

OFFSET
(Sold Separately)

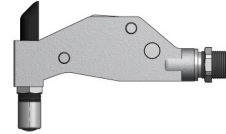

FASTENER	DIAMETER	STRAIGHT	RIGHT ANGLE (2)	OFFSET
CHERRYMAX®, CHERRYMAX® 'AB', MBC® LOCK CREATOR	1/8	456MAX-701-17 (1)	456MAX-704-54RA (1)	456MAX-704-43OS (1)
BACR15FR/FP, BACR15GF/GK	5/32	456MAX-704-35 (1)		
	3/16	456MAX-749-35 (3, 1)		
NUT PLATE RIVETS	3/32	3C-704A-16	3C-704-54RA	3C-704A-40OS
MS20600 SERIES	1/8	4C-704A-16	4C-704-54RA	4C-704A-40OS
CCR244/264/274	5/32	5C-704A-16	5C-704-54RA	5C-704A-40OS
MS/9SP/PT	3/16	6C-704A-16	6C-704-54RA	6C-704A-40OS
BACR15CC/CF/DA/DR				
'A' CODE	3/32	3A-704A-16	3A-704-54RA	3A-704A-40OS
NAS1398A	1/8	4A-704A-16	4A-704-54RA	4A-704A-40OS
NAS1399A	5/32	5A-704A-16	5A-704-54RA	5A-704A-40OS
	3/16	6A-704A-16	6A-704-54RA	6A-704A-40OS
GROUND STUD	8/32	GS8-704-16	GS8-704A-54RA	GS8-704-40OS
M83454	10/32	GS10-704A-19	GS10-704-54RA	GS10-704A-40OS
BACS53B1EA1/2				

CHERRYMAX® and MBC® are registered trademarks of Cherry Aerospace Fasteners.

GAGE BILT CERTIFIES THE GB704 WILL INSTALL THE ABOVE FASTENERS

- 1) INSTALLS 1/8", 5/32", AND 3/16" DIAMETERS
- 2) RIGHT ANGLE NOSE ASSEMBLIES MAY REQUIRE MORE THAN ONE PULL
- 3) FRONT END EJECTING NOSE ASSEMBLY.

NOTE: THE LAST 2 DIGITS OF THE NOSE ASSEMBLY REPRESENTS THE LENGTH THE NOSE EXTENDS FROM THE TOOL I.E. -20 = 2.0 INCHES

8/18

Riveter Kits (Sold Separately)

Gage Bilt offers a wide selection of standard and custom kits tailored to your needs. Contact us for more information.

RIVETER KIT
#GB704RK
(Sold Separately)



CE Approved

RIVETER KIT
#GB704RK-1
(Sold Separately)



CE Approved