

UNCONTROLLED DOCUMENT
WILL NOT BE UPDATED

REVISIONS				
REV SYM	ECO NUMBER	DESCRIPTION	BY DATE	APP'D DATE
1		ORIGINAL RELEASE	MF 3-28-11	
2		ADDED NOTE 2	MF 8-31-11	

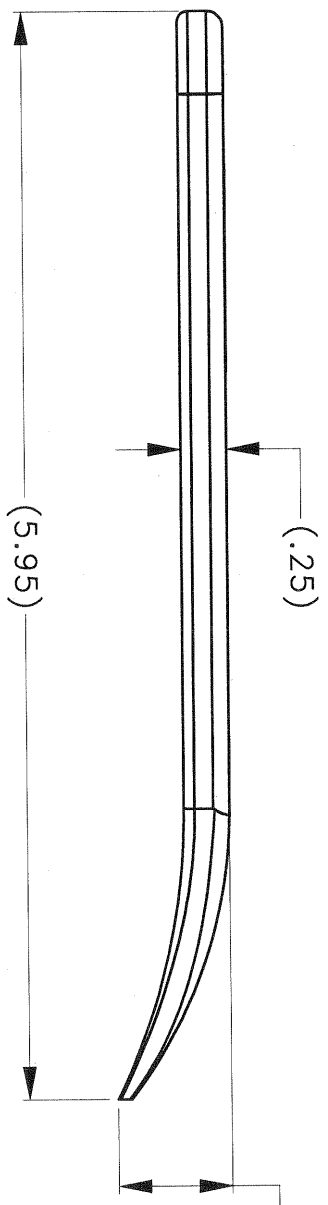
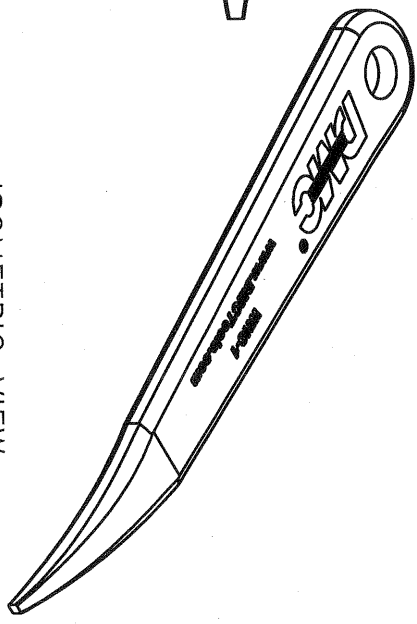

ISOMETRIC VIEW

2. NSN: 5895-01-598-1301
 1. ALL DIMENSIONS IN INCHES.
 NOTES:

RESTRICTED & CONFIDENTIAL
 CONFIDENTIAL PROPERTY OF DANIELS MANUFACTURING CORP. NOT TO BE DISCLOSED TO OTHERS, REPRODUCED OR USED FOR ANY OTHER PURPOSE EXCEPT AS AUTHORIZED IN WRITING, BY DANIELS MANUFACTURING. MUST BE RETURNED TO DANIELS MANUFACTURING CORP. ON COMPLETION OF ORDER OR OTHER PURPOSES FOR WHICH LENT.

CREATED FROM AN INVENTOR MODEL.
 CHANGES MUST BE REFLECTED IN THE 3D PART
 DO NOT SCALE DRAWING

MATERIAL	HEAT TREAT		FINISH
ITEM	PART NO.	QTY.	DESCRIPTION/REMARKS
DRN. Matt Frink	DATE 3-28-11		DMG DANIELS MANUFACTURING CORP. ORLANDO, FLORIDA CAGE 11851
CHK'D.	DATE		
APP'D.	DATE		
APP'D.	DATE		
NOTE: THIS DRAWING IS AN OUTLINE DRAWING OF THE RESPECTIVE DMC PART NUMBER INDICATED. ACTUAL DMC PART NUMBER IS DRAWING PART NUMBER WITHOUT THE "-ENV" SUFFIX			
TITLE		WHERE USED:	
DMG WIRE HARNESS SPOON ENVELOPE DRAWING		SIZE	CAD P/N
		SCALE	P/N
		1:1	WHS-1-ENV
		POSTING	WHS-1-ENV
		SHEET	OF
		1	1
		REV.	2